

APPLY LUBRICANT TO ALL SEALS  
PRIOR TO INSTALLATION.  
DO NOT USE SILICONE TYPE LUBRICANTS.  
FOR PROPER ARM MOUNTING SEE IS1505.

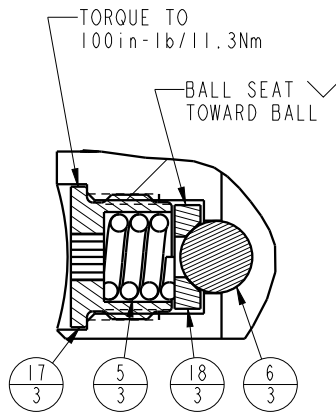

DETAIL A  
SCALE 1.500

No.	QTY	PART No.	DESCRIPTION	Std. Seal Kit	FKM Seal Kit
N/A	N/A	IS1505	INSTRUCTION SHEET, ARM INSTALLATION		
N/A	N/A	6V711042	SEAL KIT, FKM		
N/A	N/A	60711042	SEAL KIT, STANDARD		
20	1	81591828	CAM, SC, LP, 22KN, LH, LS, TC		
19	1	81541808	BASE, SC, BF, LP, 5000		
18	3	81532108	SEAT, BALL, SC, LP, TC		
17	3	81532107	RETAINER, SC, LP, TC		
16	1	81511812	PLUNGER, SC, LP, 22KN, DA, LS, TC		
15	1	39054008	BU RING, (-218)	X	X
14	1	39054007	BU RING, (-030)	X	39054021
13	1	39053005	WIPER, SNAP-IN, (1-1/4)	X	X
12	1	39051042	O-RING, (-030)	X	39V01021
11	2	39051041	O-RING, (-006)	X	39V51041
10	2	39050042	O-RING, (-011)	X	39051025
9	1	39011060	SEAL, BEVEL W/HEEL INSERT, 1-1/4 x 1/8 x 1-1/2	X	39052015
8	1	39011056	SEAL, CROWN, 1-9/16 x 1-3/4 x 5/32	X	39V11056
7	2	30601144	PLUG, SOCH, SAE 4		
6	3	23650004	BALL, TUNGSTEN-CARBIDE.250		
5	3	23350066	SPRING, COMPRESSION		
4	2	21500200	WASHER		
3	3	21500031	SHCS, M5 x 0.8 x 14, ALY		
2	10	21500023	SHCS, M5 X .8-66 X 30MM		
1	2	21500019	SCREW, CAP, BTNH, M3 X 6, ALY		

<b>PARTS LIST</b>	
	VEKTEK, INC. 1334 E. SIXTH AVE. P.O. BOX 625 EMPORIA, KS. 66801 U.S.A.
ASSEMBLIES AFFECTED 14281804 14281804F	PARTS LIST, ASSY, SC, LP, TC, BF, 5000, DA, LH, LS
SIZE A	PL7250
REV A	REV A

A	3677	RELEASE	JDW	03/04/19
REV	IN ACCORDANCE WITH ECN	EFFECTIVE DATE	REVISED BY	DATE
DRW BY:	JDW	<b>DRAWING STATUS: Released</b>		
DATE:	03/04/19	PRODUCTION APPROVED FOR RELEASED STATUS ONLY		

