

APPLY LUBRICANT TO ALL SEALS PRIOR TO INSTALLATION. DO NOT USE SILICONE TYPE LUBRICANTS. FOR PROPER ARM MOUNTING SEE IS1505.

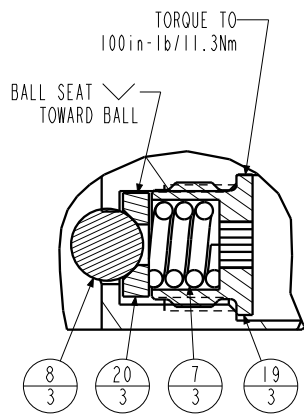

DETAIL A
SCALE 1.500

No.	QTY	PART No.	DESCRIPTION	Std. Seal Kit	FKM Seal Kit
N/A	N/A	IS1505	INSTRUCTION SHEET, ARM INSTALLATION		
N/A	N/A	6V711050	SEAL KIT, FKM		
N/A	N/A	60711050	SEAL KIT, STANDARD		
26	1	39V11051	WIPER, PRESS-IN, (1-1/2)	X	X
25	1	39V10029	WIPER, PRESS-IN, (1/4)	X	X
24	1	39H51002	O-RING, (-033)	X	39V51002
23	1	91100001	MAGNET, .130 x .312, PS		
22	1	81592136	CAM, SC, LP, 7500/33KN, RH, LS, TC, PR		
21	1	81542113	BASE, SC, BF, LP, 7500, PR		
20	3	81532108	SEAT, BALL, SC, LP, TC		
19	3	81532107	RETAINER, SC, LP, TC		
18	1	81500062	HOUSING, PS, MAG, SC, LP, LS		
17	1	81500060	ADAPTOR, PS, MAG, SC, LP		
16	1	39054017	BU RING, (-033)	X	39054023
15	1	39054016	BU RING, (1.5x.125x.063)	X	X
14	1	39052043	SEAL, LL, (1/4 X 1/8 X 1/8 X 1/2)	X	39V52043
13	1	39052030	SEAL, CROWN, 1-3/4x2-1/8x1/4	X	39V52030
12	2	39051041	O-RING, (-006)	X	39V51041
11	2	39050042	O-RING, (-011)	X	39051025
10	1	39011075	SEAL, LL, (1-1/2 X 1/8 X 1/8 1-3/4)	X	39V11075
9	2	30601144	PLUG, SOCH, SAE 4		
8	3	23650004	BALL, TUNGSTEN-CARBIDE. 250		
7	3	23350066	SPRING, COMPRESSION		
6	10	21500305	SHCS, M8 X 1.25-6G X 30MM		
5	2	21500200	WASHER		
4	1	21500044	SCREW, CAP, BTNH, M3-0.5 X 6, SSTL		
3	3	21500043	SHCS, M3-0.5 X 6 ALY		
2	3	21500031	SHCS, M5 X 0.8 X 14, ALY		
1	2	21500019	SCREW, CAP, BTNH, M3 X 6, ALY		

<h3>PARTS LIST</h3>		
	VEKTEK, INC. 1334 E. SIXTH AVE. P.O. BOX 625 EMPORIA, KS. 66801 U.S.A.	
ASSEMBLIES AFFECTED 14222103PS 14222103PSF	PARTS LIST, ASSY, SC, LP, TC, BF, 7500, DA, RH, LS, PS	
SIZE A	PL7258	REV C

C	5762	RELEASE	JDW	07/18/25
REV	IN ACCORDANCE WITH ECN	EFFECTIVE DATE	REVISED BY	DATE
DRW BY:	JDW	DRAWING STATUS: Released		
DATE:	03/04/19	PRODUCTION APPROVED FOR RELEASED STATUS ONLY		

