

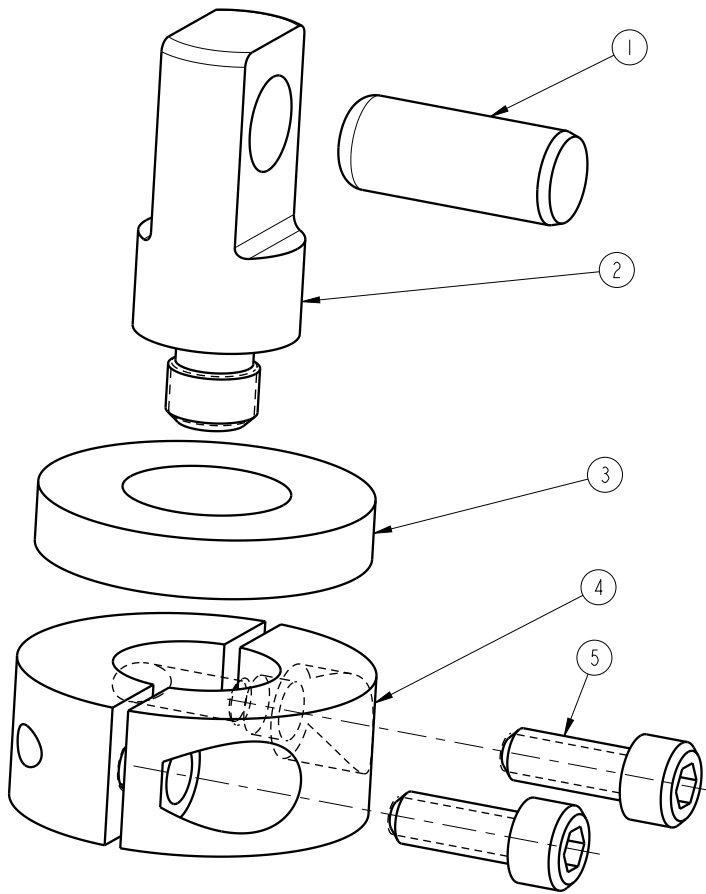

## VEKTEK ASSY, ATCH, ROCKER ARM, SC

No.	QTY	DESCRIPTION	91-5205-08 450 LB	91-5209-08 1100 LB	91-5213-08 2600 LB	91-5218-08 5000 LB
1	1	PIN, DOWEL	90199909	90199910	90199911	90199932
2	1	STUD, PIVOT	81570500	81570900	81571300	81571800
3	1	WASHER, ELASTOMER	21430005	21430006	21430007	21430023
4	1	COLLAR, CLAMP	90199906	90199907	90199908	90199933
5	2	CAPSCREW	21411014	21411035	21411003	21411003
N/A	N/A	CAPSCREW TORQUE	4 N-m / 36 in-lb	10 N-m / 91 in-lb	27 N-m / 240 in-lb	27 N-m / 240 in-lb



<b>PARTS LIST</b>	 VEKTEK, INC. 1334 E. SIXTH AVE. P.O. BOX 625 EMPORIA, KS. 66801 U.S.A.
ASSEMBLIES AFFECTED 91-5205-08, 91-5209-08 91-5213-08, 91-5218-08	PARTS LIST, ASSY, ATCH, ROCKER ARM, SC SIZE A <b>PL9101</b> REV B

B	3495	RELEASE	JDW	06/08/18
REV	IN ACCORDANCE WITH ECN	EFFECTIVE DATE	REVISED BY	DATE
DRW BY:	JDW	<b>DRAWING STATUS: Released</b>		
DATE:	07/15/13	PRODUCTION APPROVED FOR RELEASED STATUS ONLY		